

# STICK 500 / 700

## SPECIFICATIONS

MOUNTING		GROUND
POWER	[W]	7
LAMP		built-in LED
LUMINOUS FLUX*	[lm]	960
LIGHT COLOUR	[K]	3000
CRI		>90
BEAM ANGLE	[°]	25
AVERAGE LIFETIME	[h]	L80/B50.000
LUMINOUS EFFICACY	[lm/W]	137
POWER SUPPLY	[V] [A]	220-240V AC 50/60 Hz
LED-DRIVER		INCLUDED
DIMMING		NO
THROUGH-WIRING		YES (JUNCTION BOX IV)
MATERIAL		ALUMINUM
INGRESS PROTECTION		IP65
PROTECTION CLASS		I
NET WEIGHT	[kg]	1,20
GROSS WEIGHT	[kg]	1,28
COLOUR (HOUSING)		BLACK ~RAL9005
OUTLET CABLE		2,5m H05RN-F 3x0,75mm <sup>2</sup>



## LIGHT DISTRIBUTION

25°

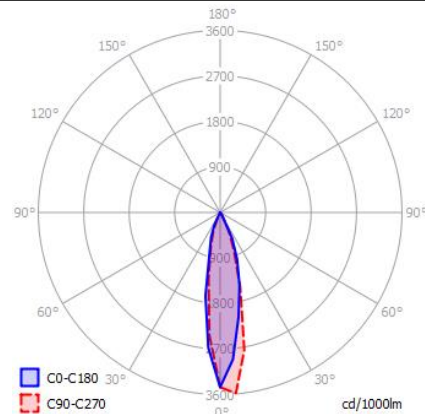

\*Luminous flux values are nominal LED data at a operating temperature of 25° C

## OPTIONS / OPTIONAL ACCESSORIES

MICRO JUNCTION BOX	II	BLACK
MICRO JUNCTION BOX	IV	BLACK

## Colours

black



## MOUNTING DIMENSIONS

n/a

## FIXTURE DIMENSIONS

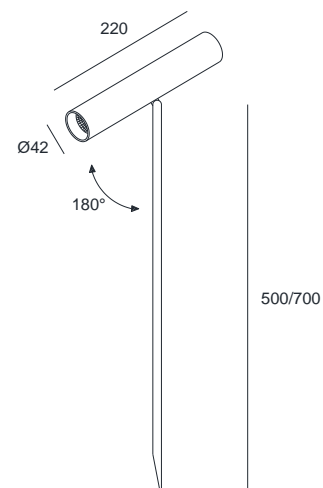

DLS LIGHTING

www.dslighting.com

**\*DLS**  
LIGHTING